

PRODUCT CATEGORY

OIL SEPERATOR

PRODUCT NAME

LARGE SMX SERIES

APPLICATION

Petrol Station & Depot

CAPACITY

250L/min and above

PLANT DESCRIPTION

Siemex oil separators base separation systems that utilize stable media to recover liquid hydrocarbons from oily water streams. Oil and water separate as they travel under laminar flow stream through highly efficient coalescer media providing a high separation area for effective coalescence. Without moving parts, low maintenance and small footprint is guaranteed.

Feature

- Robust tank and support frame
- Coalescing plate pack
- Oil collection pipework
- Solids collection hopper and drain valve
- Effluent oil storage drum or optional tank
- DOE standard A effluent discharge
- Optional level control system and oil skimmer for collection pit
- Optional skid mount and access platform
- Above or below ground installations

APPLICATION

- Refueling aprons
- Petroleum storage installations
- Petrol service stations
- Car and vehicle workshops
- Car wash / engine wash
- Heavy vehicle & light vehicle wash bays for heavy industries
- Mechanical/Engineering workshops
- Industrial equipment wash-down
- Contaminated storm-water treatment

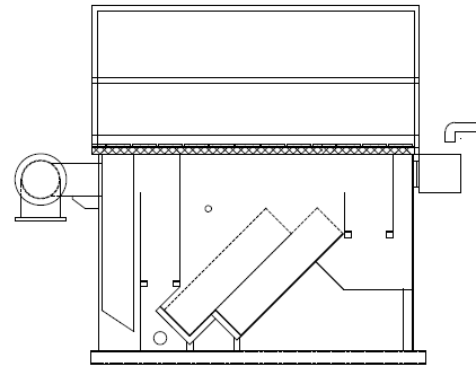
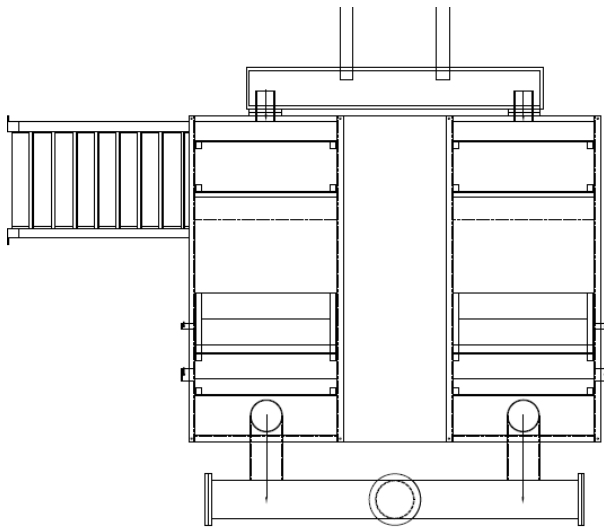

SMX1000 above ground

PLAN VIEW

SECTION A-A

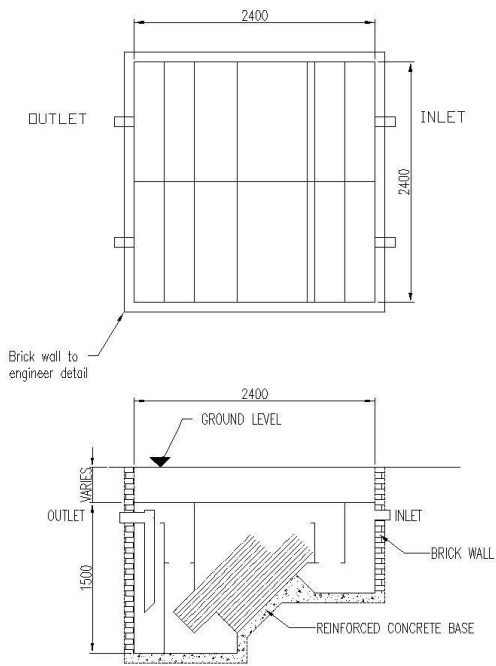

SMX1000

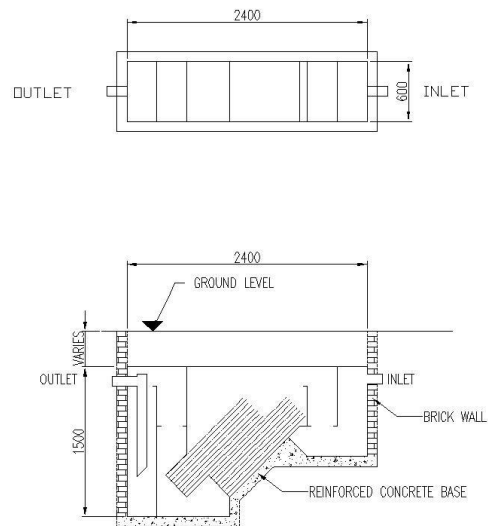

SMX250

SMX SERIES DIMENSION

CAPACITY	WIDTH	LENGTH	HEIGHT
250L/min	600	2400	1500
500L/min	1200	2400	1500
750L/min	1800	2400	1500
1000L/min	2400	2400	1500

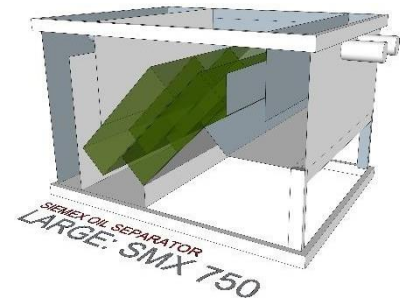
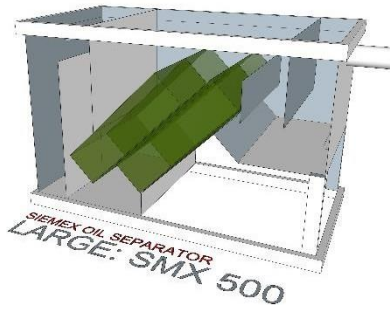
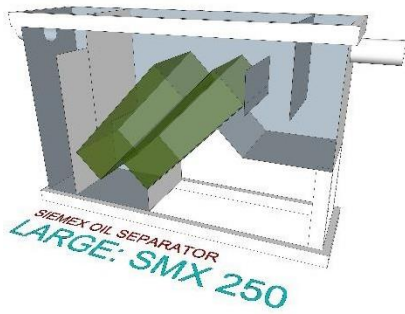

PLEASE CONTACT US FOR CUSTOM SIZING

HYDRAULIC PROFILE

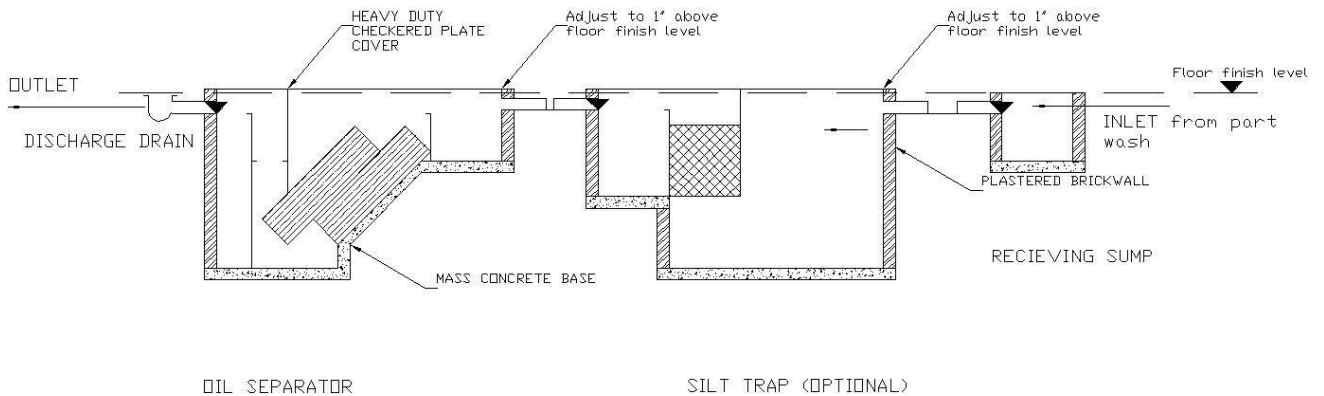

HHC Industries SDN BHD
 No. 234, Jalan Kip 7, Taman Perindustrian Kip, 52200 Kuala Lumpur,
 Selangor, Malaysia
 Tel: +603-3285 5883 Fax: +603-3285 5883
 Website: <http://www.hhcindustries.com.my>